

SRK-100 Thermal Mass Flow Meter

1. Overview

The advanced technique of Silver Automation Instruments has been introduced to produce this flow meter measuring gas mass flow. Traditional flow meters need to adopt temperature and pressure compensation for measurement of fluid mass flow, whereas this flow meter can directly measure fluid mass flow without requiring temperature and pressure compensation. Its conspicuous features are as follows: direct trade settlement, no movable components, small pressure loss, wide range ratio, high accuracy, high reliability, simple installation and convenient operation. It is extensively used in the industries such as petroleum, chemical industry, medical industry, heat power plant and environmental protection etc.



2. Typical Applications

- Flow measurement of gas in industrial pipelines
- Flow measurement of air during gas combustion
- Flow measurement of flue gas out of chimneys
- Flow measurement of waterfall gas during water treatment
- Flow measurement of gas and compressed air during production of cement, cigarette and glass
- Flow measurement of natural gas, coal gas, liquefied gas, flare gas and hydrogen gas etc.
- Flow measurement of trapped gas in steelworks

3. Operating Principle

SRK-100 Series thermal gas mass flow meter employs thermal diffusion principle. The thermal diffusion technique is that of excellent performance and high reliability under severe conditions. The typical sensing elements include two thermal resistances (platina RTD); one is a velocity sensor and the other is a temperature sensor for automatic compensation for gas temperature variation. When the two RTDs are placed in medium, the velocity sensor is heated to a constant difference in temperature above ambient temperature, and the temperature sensor is used to respond to the medium temperature. If gas velocity increases, the heat quantity transmitted to the medium from the sensor will increase, so there is a need for more supply of power, whereas the power for electronic elements to heat RTD is corresponding with mass flow to a certain extent.

4. Technical Specifications

Accuracy	$\pm 1\%$ reading; $\pm 0.5\%$ full range
Repeatability	$\pm 0.5\%$ of full range
Turn down ratio	Normal 100:1; it is decided by calibrated flow range
Upper Limit of Range	80 Nm/s (air,20°C,101.33kPa)
Lower Limit of Range	0.05Nm/s (air,20°C,101.33kPa)
Size	Ø6~ Ø6000
Pressure Range	Negative Pressure, 0~1.0MPa,0~1.6MPa,0~2.0MPa,0~3.0MPa
Medium Temperature	-20~60°C,60~100°C,100~150°C,150~200°C,200~300°C
Medium	All kinds pure gas or mixed gas with fixed percentage, gas with dust, sand or moisture, corrosive gas
Sensor Diameter	Ø3(standard), Ø4
Sensor Material	316SST,hastelloy,titanium
Probe Stem Diameter	Ø19(standard), Ø16, Ø12
Probe Stem Material	316SST,hastelloy,
Power supply	24VDC/400mA or 220VAC/2W
Output	4-20mA DC, max load 1000Ω;RS485,Hart
Display	LED; four digits instantaneous flow , eight digits totalized flow
Correction	16 non-linearity correction
Type	Remote type: transmitter + flow totalizer Integral type: transmitter with integral totalzier
Installation Type	Insertion type and In-line type
Alarm	1-2 relay output,3A/220VAC,3A/30VAC,settable
Protection level	IP65
Explosive proof	Ia IICT65,ExdII CT4
Lifetime	5 years

5. Dimension

SRK-100 Thermal mass flow meter dimension shown as following:

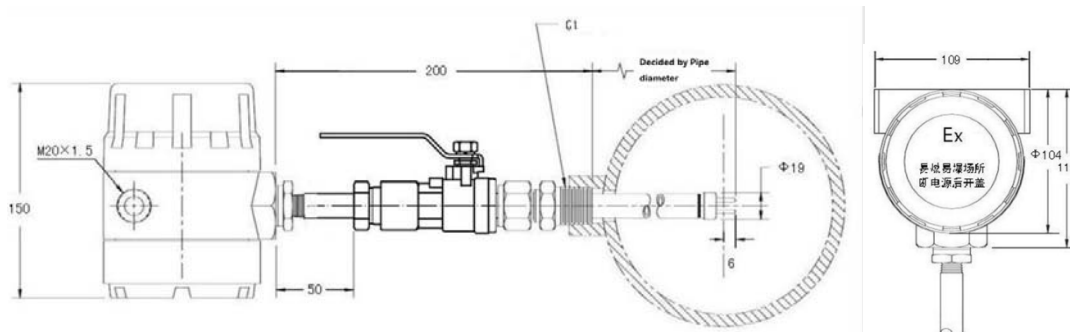

Figure 1-1: Dimension of Insertion Type Thermal Mass Flow meter

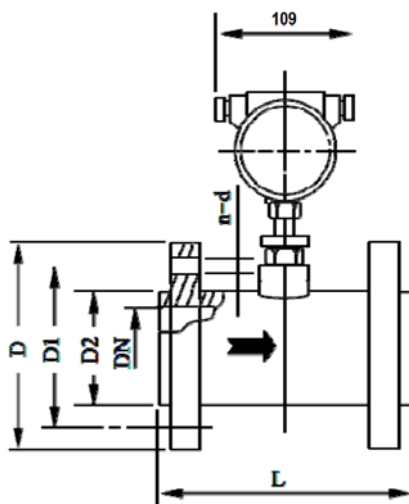

Figure 1-2: Dimension of Flange Connection Thermal Mass Flow meter

Table 1

Nominal Diameter	Length Unit (mm)	Flange Dimension				
		Flange OD	Bolt Circle Diam	Sealing Face	Bolt Specifi.	Nominal Pressure
DN	L	D	D1	D2	n-d	PN
15	160	95	65	46	4-φ 14	4.0
20	160	105	75	56	4-φ 14	4.0
25	160	115	85	65	4-φ 14	4.0
32	200	140	100	76	4-φ 18	4.0
40	200	150	110	84	4-φ 18	4.0
50	200	165	125	99	4-φ 18	4.0
65	200	185	145	118	4-φ 18	4.0
80	200	200	160	132	8-φ 18	4.0
100	200	220	180	156	8-φ 18	4.0

Flange Standard: GB/T 9119-2000, if you need other standard flange, please specifies.

6. Model Selection Guideline

6.1 Flow range and Flow meter size selection

1. Table Reference

Table2: Four kinds common gas calibrated range selection table

Table3: Common gas upper limit

All flow meters are calibrated before leaving factory, the upper limit of flow range will be indicated on the name plate of flow meter.

2. Lower and upper limit of the flow range

- 1) Lower limit: the thermal mass flow meter is sensitive to low flow, it can detect 0.05 m/s flow rate, so in normal condition, lower limit can be ignored.
- 2) Upper limit: It is normally decided by process design; the flow meter upper limit is more than 20% of design limit.
- 3) Mixed gas measurement: For mixed gas, the ender user should provide standard density and mole ratio (different gas percentage of the mix gas). The measuring range is decided by our factory. It is normally calibrated by air or nitrogen, and then corrected by meter conversion coefficient.

3. Statement

The flow range is limited by equipment; please get confirmation from factory before purchasing.

Four kinds common gas calibrated range selection table (Nm³/h)

Table2

DN(mm)	Air	(N ₂)	(O ₂)	(H ₂)
15	65	65	32	10
25	175	175	89	28
32	290	290	144	45
40	450	450	226	70
50	700	700	352	110
60	1200	1200	600	185
80	1800	1800	900	280
100	2800	2800	1420	470
125	4400	4400	2210	700
150	6300	6300	3200	940
200	10000	10000	5650	1880
250	17000	17000	8830	2820
300	25000	25000	12720	4060
400	45000	45000	22608	7200
500	70000	70000	35325	11280

600	100000	100000	50638	16300
700	135000	135000	69240	22100
800	180000	180000	90432	29000
900	220000	220000	114500	77807
1000	280000	280000	141300	81120
1200	400000	400000	203480	91972
1500	600000	600000	318000	101520
2000	700000	700000	565200	180480

Note: The flow unit in above table is Nm³/h, corresponding flow rate is 34m/s,when in application, it can expand to 50m/s

Common gas upper limit (Nm³/h)

Table3

DN (mm)	Argon (Ar)	Helium (He)	Natural Gas	Methane Gas	LPG	City Gas	Chlorine Gas
25	82	37	58	51	84	44	109
40	207	94	147	129	211	111	273
50	331	151	235	206	339	177	436
80	828	378	588	516	847	444	1092
100	1380	630	980	860	1143	740	1820
150	2760	1260	1960	1720	2826	1480	3640
200	5520	2520	3920	3440	5652	2960	7280
250	8280	3780	5880	5160	8478	4440	10920
300	11923	5443	8467	7430	12208	6393	15724
400	21196	9676	15052	13209	21703	11366	27955
500	33120	15120	23520	20640	33912	17760	43680
600	47692	21772	33868	29721	48833	25574	62899
700	64915	29635	46099	40454	66467	34809	85612
800	84787	38707	60211	52838	86814	45465	111820
900	107308	48988	76204	66873	109874	57542	141523
1000	132480	60480	94080	82560	135648	71040	174720
1200	190771	87091	135475	118886	195333	102297	251596
1500	298080	136080	211680	185760	305208	159840	393120
2000	529920	241920	376320	330240	542592	284160	698880

Standard state: temperature 0 °C, Pressure 1.01325×10⁵Pa (absolute pressure)

Flow unit option: kg/h,t/h,Nm³/h,Nkm³/h.

6.2 Installation types

1. Recommendation:

When the pipeline $\leq \varnothing 100$, Flange type is recommended.

When the pipeline $> \varnothing 100$, Insertion type is recommended.

2. If the field pipes have been installed,, no installation flanges available, Insertion type can be selected. Please specify when ordering.

6.3 Construction Types

1. Compact type:

The sensor, transmitter, display are integral, Power supply can be 220VAC or 24VDC. The display unit can display instantaneous flow and totalized flow, set alarm point and output 4-20mA.



Figure 2: Compact Type

2. Remote type

The sensor, transmitter, and display are not integral. The display unit can display instantaneous flow and totalized flow, set alarm point and output 4-20mA. The two parts are connected by three wires, and the transmitters are 3 wire type.



Figure 3: Remote Type

6.4 Output Type

- Linear output: standard 4-20mA linear output;
- The display unit output 4-20mA, the flow range can be set manually. For example, the flow meter measuring range is 0~5000 Nm³/h, it output 4-20mA, the display unit can set 0-3000Nm³/, 100~1500 Nm³/h... then output corresponding 4-20mA signal.
- Cut off small flow. For some customers, cut-off small flow is required.
- Output filter: when the gas is flowing in the pipeline, there are vibrations for some reason, the output figures on the display are fluttering, filter factor can be increased to decrease the fluttering.
- Communication port: RS485 or alarm output. Customer needs to specify when ordering.
- Hart Protocol

6.5 Measuring Unit and Flow Unit Conversion Table

1. Normal used mss flow unit: kg/h;

Standard volume unit: Nm³/h

2. When the flow range is large, please select t/h or Nm³/h

When the flow range is small, options are following:

Standard milliliter per minute: ml/min, symbol: SCCM

Standard liter per minute: L/min, symbol: SLM

Standard cubic meter per minute: Sm³/min

In industry, following units can be adapted.

Table 4

			Symbol	Implication
Flow	Metric system	Volume	SCCM	Standard milliliter/ minute
			SLM	Standard liter /minute
			SL/min NL	Standard liter /minute
			SM ³ /min NCM	Standard cubic meter /minute
	British System	Mass	kg/time	Kilogram/unit time
			TNS/time	Ton/time
			SCF/time	Standard cubic foot/ time
			LB/time	Pound/ time
Flow rate		NM/time	Standard meter/ time	
		SF/time	Standard feet/time	
Conversion		1SCFM=28.316SL/min 1 Standard cubic foot =0.0283SM ³ /min		
Length Unit Conversion		1inch=25.4mm 1cm=0.394inch 1ft=30.5cm 1m=3.28ft		
Symbol:		LB—pound	kg—Kilogram	TNS—Ton

Flow Unit Conversation Table

7. Model Selection

Table 5

Item	Code	Description		
Product Code	SRK-100	SRK-100 Series Thermal Mass Flow meter		
Pipe size	DN	Ø6~ Ø6000		
Construction	F	Remote Type		
	I	Compact Type		
Sensor Structure *1	PI	Insertion Type	W	Weld base
			B	Base + ball valve
	PL	In-line Type	F	Flange
			T	Thread
			C	Compression fitting
Probe Diameter	19	Ø19(standard)		

	16	Ø16
	12	Ø12
Probe Material	6	316
	F	PTFE coated
	Y	Others
Explosive Proof	A0	NO
	A1	With Explosive Proof
Temperature	T0	-20~60 °C
	T1	60-100°C
	T2	100-150°C
	T3	150-200°C
	T4	200-300°C
Pressure	P0	Negative Pressure
	P1	0-1.0Mpa
	P2	0-1.6Mpa
	P3	0-2.0Mpa
	P4	0-3.0Mpa
Power Supply	D	24VDC
	A	220VAC
	0	Other
Output	0	No output
	1	4-20mA
	2	RS485,Modbus
	3	Hart Protocol
Alarm	A0	No alarm
	A1	1 alarm relay output
	A2	1 alarm relay outputs
Display	N	No display
	E	LED

Note:

*1, For example: Code PIW---Insertion type flow meter with weld base.