

SH-CMF-Coriolis Mass Flow Meters



Principle

The structure of Coriolis Mass Flow Meters was consisted of a pair of bended tubes. The principle is to detect Coriolis force which is forced on a pair of tubes from inner mass flow by fluid.

A new force-Coriolis force would be appearing while two conditions are met:

- a. Vibrating with normal frequency in a pair of bended tubes,
- b. Fluid flowing in tubes. This force was produced upon synthesis from vibrating force and flowing force by fluid in tubes. And tubes would be wresting symmetric the center line because the force forced.

Two displacement sensors on sides of tubes detect the force and output electric signals.

The signals regulated and mass flow directly produced.

Main Technical Parameters

- Medium: liquid, gas, solid, or two phases mixed fluid
- Flow Accuracy : $\pm 0.2\%$ ~ $\pm 0.1\%$ flow
- Density Accuracy: $\pm 0.002\text{g/cm}^3$, $\pm 0.001\text{g/cm}^3$
- Repeatability: $\pm 0.10\%$, $\pm 0.05\%$
- Operation Pressure: (0~32) MPa (in case of other high pressure, it must be of special order)
- Medium Temperature : -50°C ~ $+350^\circ\text{C}$,
- Environment temperature : -20°C ~ $+70^\circ\text{C}$ for transmitters , and -40°C ~ $+150^\circ\text{C}$ for sensors
- Output signal:
 - (1) 4-20mA current signal of flow, with load resistance $\leq 500\Omega$
 - (2) 0-10KHz, frequency signal of instant flow.

(3) RS485 Communication protocol

(4) Hart protocol

- Power supply voltage: 24VDC
- Material of measuring Tube: 316L stainless steel or hastelloy alloy C
- Response time: 0.1s~5s, adjustable
- Explosion-proof grade: EX d ib II C T5 Gb

Flow Range

DN	Flow Range	Operation Pressure	Process Connection
1.5	0~4 kg/h	0~32 Mpa	Weld Joints Φ6×1.5
3	0~40 kg/h	0~32 Mpa	Weld Joints Φ6×1.5
6	0~100 kg/h	0~25 Mpa	Weld Joints Φ10×2
8	0~200kg/h	0~20 Mpa	Weld Joints Φ10×1
10	0~0.5 T/h	0~4 Mpa	Flange DN10
15	0~1.0 T/h	0~4 Mpa	Flange DN15
20	0~3.0 T/h	0~4 Mpa	Flange DN20
25	0~10 T/h	0~1.6 Mpa	Flange DN25
40	0~20 T/h	0~1.6 Mpa	Flange DN40
50	0~30 T/h	0~1.6 Mpa	Flange DN50
65	0~50 T/h	0~1.6 Mpa	Flange DN65
80	0~100 T/h	0~1.6 Mpa	Flange DN80
100	0~150 T/h	0~1.6 Mpa	Flange DN100
125	0~200 T/h	0~1.6 Mpa	Flange DN125
150	0~400 T/h	0~1.6 Mpa	Flange DN150
200	0~500 T/h	0~1.6 Mpa	Flange DN200

Model Selection

SH-CMF			Silver Coriolis Mass Flow Meters		
Model	Nominal Diameter	Flow range(t/h)	Model	Nominal Diameter	Flow range(t/h)
1.5	DN1.5	0~4 kg/h	40	DN40	0~20 T/h
3	DN3	0~40 kg/h	50	DN50	0~30 T/h
6	DN6	0~100 kg/h	65	DN65	0~50 T/h
8	DN8	0~200kg/h	80	DN80	0~100 T/h
10	DN10	0~0.5 T/h	100	DN100	0~150 T/h
15	DN15	0~1.0 T/h	125	DN125	0~200 T/h
20	DN20	0~3.0 T/h	150	DN150	0~400 T/h
25	DN25	0~10 T/h	200	DN200	0~500 T/h
P	Pressure				
P1	1.6 Mpa				

P2	4.0MPa	
P3	32MPa	
P5	25Mpa	
P6	20Mpa	
P4	Special demand	
A	H	Structure Form
	H1	Compact
	H2	Remote
	T	Temperature
	T1	(-50~150 °C)
	T2	(-50~250 °C)
	T3	(-50~350 °C)
	T4	(-200~150 °C)
	O	Output
	O1	4~20mA
	O2	Frequency/pulse
	O3	0~5V
	C	Communication
	C1	None
	C2	RS485/Modbus
	C3	Hart
	E	Hazardous Area
	E1	Intrinsically safe, Exib[ib]IICT5 Gb
	A	Accuracy
	A1	0.15%
	A2	0.2%
	A3	0.1%
	B	Batch Control
	B1	None
	B2	With Batch Control
	P	Power supply
	P1	24V DC
P2	220V AC	
M	Tube Material	
M1	316L	
M2	Hastelloy alloy C	
M3	Others	
PC	Process Connection	
PC1	Flange(specify standard)	
PC2	Tri-clamp	
PC3	Weld thread(Specify thread)	
PC4	Others	

* Please provide density, temperature of the medium, also cable length (if needed) when ordering

Dimensions

Transmitter Size

Integral Type

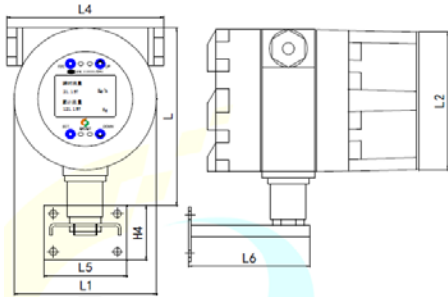

L	L1	L2	L4	L5	L6	H4
156	125	118	130	70	102	46

Unit : mm

Remote Type (with batch control)

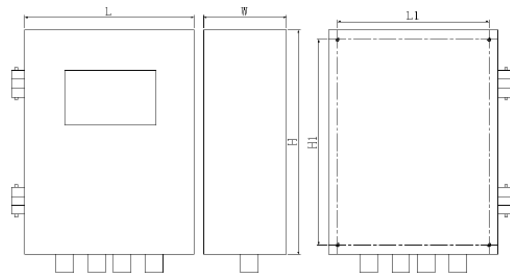

L	W	H	H1	L1
190	95	251	229	170

Unit: mm

Sensor size

DN1.5~DN8 unit:mm

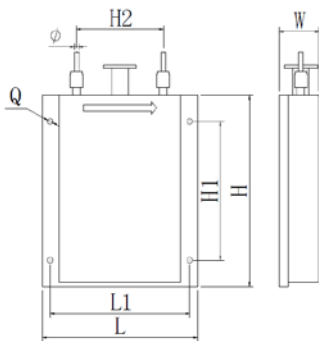

DN	Φ	L	L1	H	H1	H2	W	Q
1.5	6	205	185	220	160	115	52.5	7
3	6	205	185	220	160	115	52.5	7
6	10	205	185	220	160	115	52.5	7
8	10	208	188	245	185	117	58.5	7

Unit: mm

DN10~DN150 unit :mm

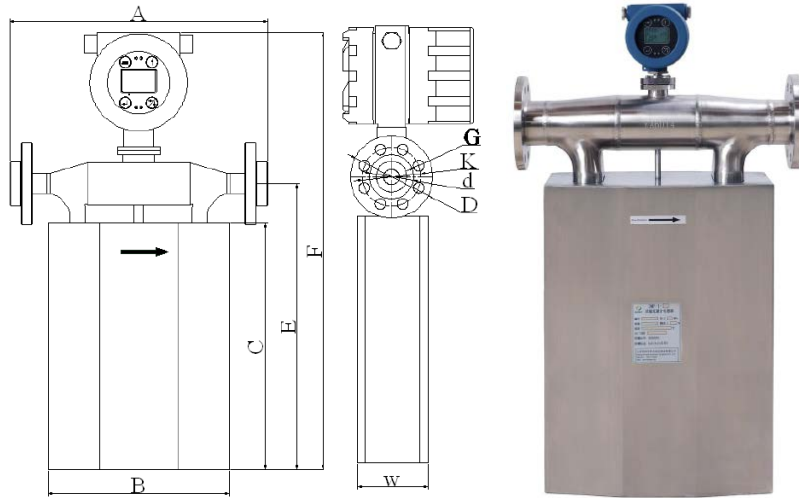

DN	Mpa	A	B	C	E	F	W	G	K	d	D
10	4.0	280	210	235	285	485	80	14	60	41	90
15	4.0	280	210	275	325	525	80	14	65	46	95
20	4.0	290	230	325	375	575	90	14	75	56	105
25	4.0	410	300	440	500	696	120	14	85	65	115
40	4.0	520	360	480	585	790	130	18	110	84	150
50	4.0	550	370	548	670	875	153	18	125	99	165
65	4.0	560	440	600	715	836	200	18	145	118	185
80	2.5	660	470	650	767	988	220	18	160	132	200
100	2.5	670	490	720	831	1052	220	22	190	156	235
125	1.6	700	510	790	908	1142	260	18	210	184	250
150	1.6	900	700	930	1110	1350	280	22	240	211	285

DN10, 15, 20, 40, 65,100,125,150, slip on flange, flange standard China Standard GB/T91112-9124-2000

DN25, 50, 80 lap joint flange, flange standard China Standard GB/T9112-9124-2000

Please specify flange standard when ordering if customer needs special flange demand.

High Pressure Flow meter unit:mm

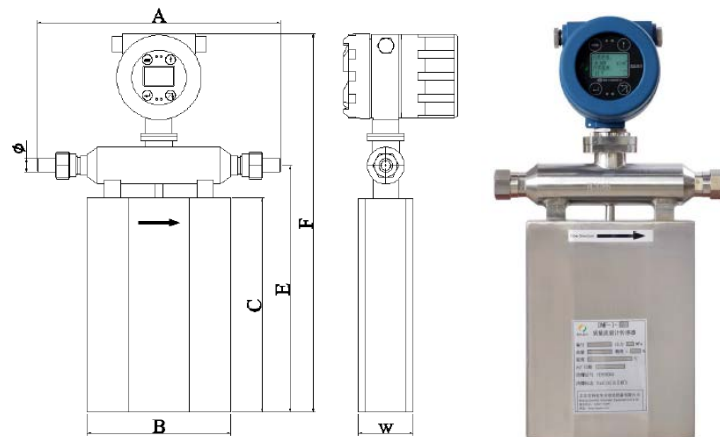

DN	Mpa	A	B	C	E	F	W	Φ
10	25	346	210	235	282	482	80	20×4
15	25	356	210	275	322	522	80	20×3
20	25	376	230	325	372	572	90	20×2
25	25	460	300	440	500	696	120	31×3

Process connection is weld joint

Bent Series unit:mm

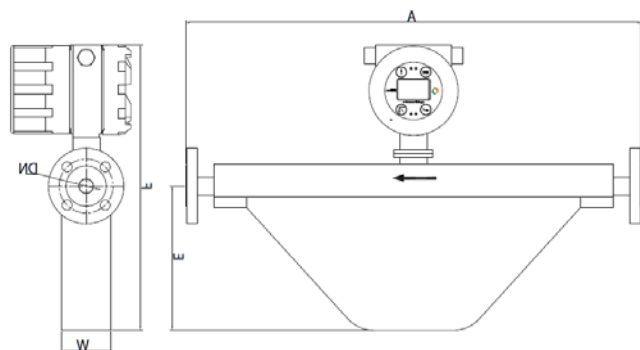

DN	A	E	W	F
10	550	160	68	360
15	580	170	68	370
20	640	200	68	400
25	780	320	100	520
50	900	230	108	460
80	995	260	140	515
100	1300	350	150	605
150	1750	490	262	805
250	1920	510	262	825

Technical Specification

Instant Flow Accuracy: $\pm 0.2\%$, flow $\pm [(zero\ stability/flow\ value) \times 100]\%$

Flow response time: 1 second (adjustable)

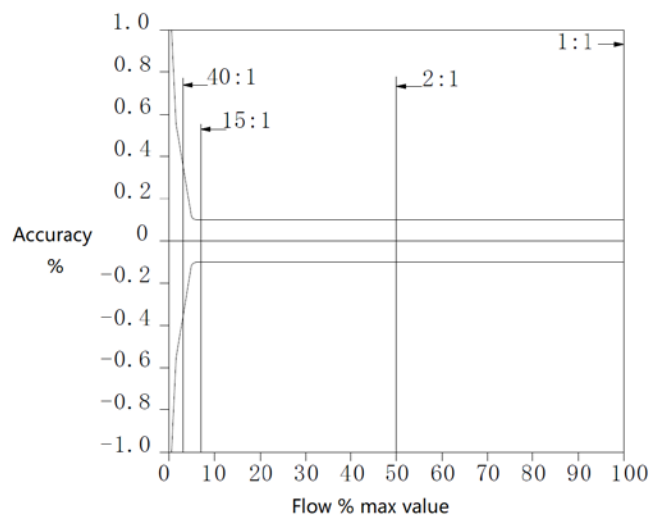

Density Accuracy: $\pm 0.002\text{g/cm}^3$ (liquid)

Density Range: $0.5\text{--}2.5\text{ g/cm}^3$

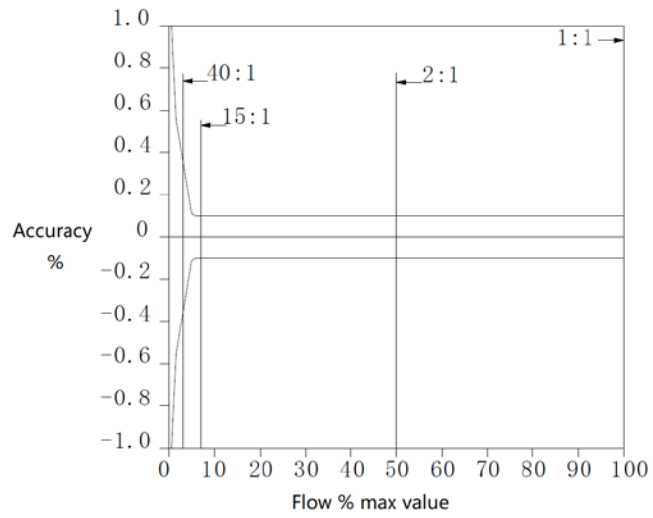

Temperature Accuracy: $\pm 1^\circ\text{C}$

